

Honeywell

Zio[®] LCD Wall Modules

TR70, TR71 and TR75 models with Sylk[®] bus

INSTALLATION INSTRUCTIONS



PRODUCT DESCRIPTION

The Zio Series (TR70/TR70-H, TR71/TR71-H, TR75/TR75-H) are 2-wire, non-polarity sensitive, Sylk bus communicating wall modules for use with Spyder[®] Classic, Stryker[®] CIPer[™] 30 and ComfortPoint[™] programmable controllers.

All models have a space-temperature sensor, network bus jack, and an LCD panel with three softkeys and two Up/Down adjustment keys. The TR70-H, TR71-H and TR75-H models include an onboard humidity sensor.

NOTES:

1. Refer to the *Zio LCD Wall Modules – Specification Data*, form 63-1322, for specific model features and additional information.
2. Refer to the *Zio LCD Wall Modules – Operating Guide* (Form 63-2719) for information about customizing the wall module configuration, such as modifying the default Home screens or creating your own application.

FEATURES

The Zio wall modules include:

- **Ability to control user access to controller parameters, including password protection on TR71 and TR75 models.**
- **Ability to assign labels for enumerated values.**
- **Customized parameter access, by using the WEBS-AX[™] and WEBS-NX[™] Workbench tool.**

- **Ability to link setpoint limits to a network variable.**
- **Programmable for: home screen options, tenant access, contractor access, access to controller parameters, setpoint, override, fan, and other parameters.**
- **TR70 and TR71 have the ability to access and adjust virtually any parameter in the programmable controller (except Scheduling).**
- **TR75 can additionally access and adjust the controller schedule.**
- **The TR71 has roughly twice the memory capacity for parameters as the TR70, and the TR75 has more than twice the memory capacity for parameters as the TR71.**
- **Ability to balance the VAV system from the wall module.**
- **Home screen can display one to three of any of the following parameters: temperature setpoint, room temperature, room humidity, outdoor humidity, outdoor temperature, and time, or one of virtually any parameter in the controller.**
- **Network bus jack.**
- **Simple 2-wire terminal connection to the programmable controller and an optional 2-wire terminal connection for the network. All connections are polarity insensitive.**
- **Permanent retention of user configuration, including setpoints after a power outage.**

SPECIFICATIONS

Models: TR70, TR71, TR75.

TR70-H, TR71-H and TR75-H include an onboard humidity sensor.

Environmental Ratings:

- Operating Temperature: 30°F to 110°F (-1°C to 43°C)
- Shipping Temperature: -40°F to 150°F (-40°C to 65.5°C)
- Relative Humidity: 5% to 95% non-condensing

Accessories:

50007298-001 (pack of 12) medium, cover plate; 6-7/8 x 5 in. (175 x 127 mm).

Approvals: CE; UL94-HB plastic enclosure; FCC Part 15, Class B



62-0271-11

Communications

The wall modules use a sensor bus (S-BUS) for communications with the programmable controller. Wire the two S-BUS terminals according to these installation instructions.

The wall modules have a network bus port for LONMARK® or BACnet® communications. If network communication is needed, connect the building LON network wires to the two terminals (NET-1 and NET-2), according to these installation instructions. A network bus port is accessible at the bottom of the wall module by removing the jack plug. See Fig. 1.

The network bus and S-BUS terminals (see Fig. 6 on page 4) are insensitive to polarity, minimizing installation errors due to mis-wiring.

BEFORE INSTALLATION

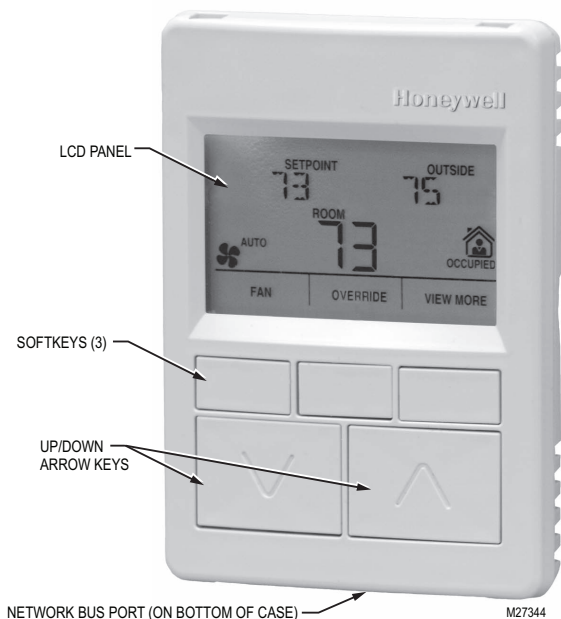

Fig. 1. LCD Wall Module features.

CAUTION
Erratic System Operation Hazard.
Failure to follow proper wiring practices can introduce disruptive electrical interference (noise).
 Keep wiring at least one foot away from large inductive loads such as motors line starters, lighting ballasts, and large power distribution panels. Shielded cable is required in installations where these guidelines cannot be met. Ground the shield only to the grounded controller case.

INSTALLATION

Mount the wall module on an inside wall approximately 54 in. (1372 mm) from the floor (or in the specified location), to allow exposure to the average zone temperature. Do not

mount the wall module on an outside wall, on a wall containing water pipes, or near air ducts. Avoid locations that are exposed to discharge air from registers or radiation from appliances, lights, or the sun.

The wall module can be mounted on a wall, on a standard utility conduit box using No. 6 (3.5 mm) screws or on a 60 mm wall outlet box (see Fig. 3). When mounting directly on a wall, use the type of screws appropriate for the wall material.

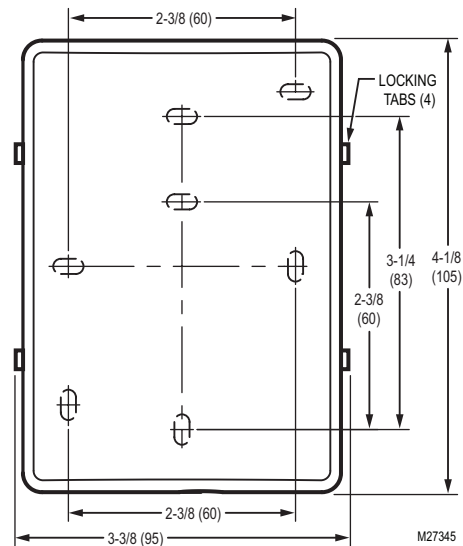

Fig. 2. Subbase mounting holes and locking tabs.

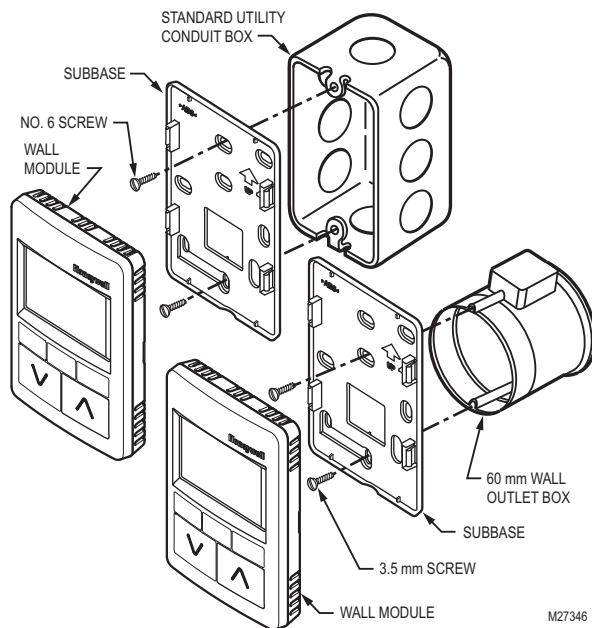

Fig. 3. Mounting on standard utility conduit box or 60 mm wall outlet box.

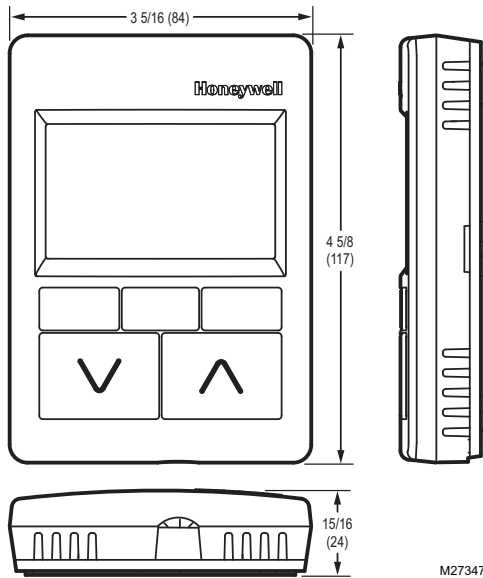

Fig. 4. LCD Wall Module dimensions in inches (mm).

Wiring

IMPORTANT

All wiring must comply with local electrical codes and ordinances or as specified on installation wiring diagrams.

- All wiring is polarity insensitive.
- The cover for the wall module is packed separately from the subbase for ease of installation.

The LCD wall module is shipped with its mounting plate (subbase) separate from the module. All terminal connections can be made to the backside of the module. There are no field adjustable/replaceable components inside the module.

Attach the wires from the programmable controller and network to the appropriate wall module terminals, as indicated in Fig. 6 on page 4.



CAUTION

Improper Electrical Contact Hazard.
Screw-type terminal blocks are designed to accept no more than one 18 AWG (0.82 sq. mm) conductor.

Connect multiple wires that are 18 AWG (0.82 sq. mm) with a wire nut. Include a pigtail with this wire group and attach the pigtail to the individual terminal block.

Wiring Wall Modules

Wire the terminal block shown in Fig. 6 as follows:

1. For single wires, strip 3/16 in. (5 mm); for multiple wires going into one terminal, strip 1/2 in. (13 mm) insulation from the conductor. See Fig. 5 for wiring multiple Zios.
2. Insert the wire in the required terminal location and tighten the screw to complete the termination.
3. Review and verify the terminal connection wiring illustrated in Fig. 6.
4. Recommended wire is single twisted pair, non-shielded, 18-24AWG, stranded or solid. Standard thermostat wire, non-twisted, 18-24AWG, solid or stranded can also be used. See Table 1 for recommended maximum distance.

Table 1.

| Quantity and type of device ^a | Recommended maximum distance from controller to any Sylk device | | |
|---|---|----------------|---|
| | Single twisted pair, non-shielded, stranded or solid ^b | | Standard thermostat wire, (non-twisted), shielded or non-shielded, stranded or solid ^{c,d} |
| | 18-22 AWG | 24 AWG | 18-24 AWG |
| 10 wall modules, any type | 500 ft (150 m) | 400 ft (120 m) | 100 ft (30 m) |
| 4 Sylk field devices of any type (including Zelix) | 400 ft (120 m) | 300 ft (100 m) | 100 ft (30 m) |
| 10 Sylk field devices of any type (excluding Zelix) | 400 ft (120 m) | 300 ft (100 m) | 100 ft (30 m) |

^a For Spyders, use the Resource Usage View in the Spyder Tool to determine the maximum number of devices. For ComfortPoint™ Open controllers, there is a maximum of 3 TR40/42s.

^b As a rule of thumb, single twisted pair (2 wires per cable only), thicker gauge, non-shielded cable yields best results for longer runs.

^c The 30 m distance for standard thermostat wire is conservative, but meant to reduce the impact of any sources of electrical noise (including but not limited to VFDs, electronic ballasts, etc). Shielded cable recommended only if there is a need to reduce the effect of electrical noise.

^d These distances also apply for shielded twisted pair.

TWO WIRES INTO ONE TERMINAL

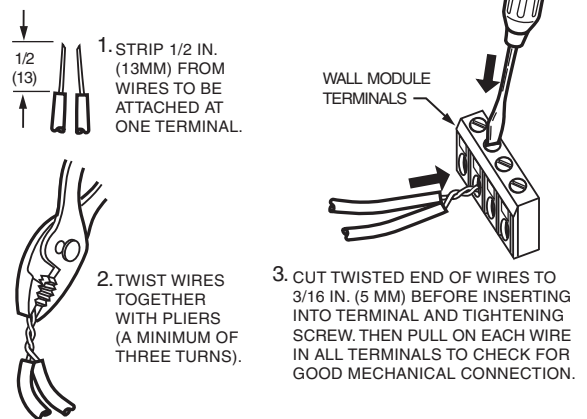

DAISY-CHAINING MULTIPLE ZIOS

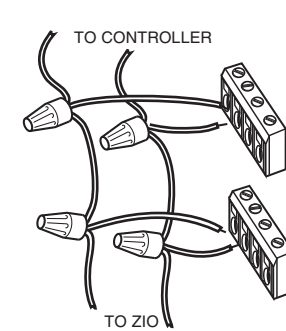

HOME RUNNING MULTIPLE ZIOS

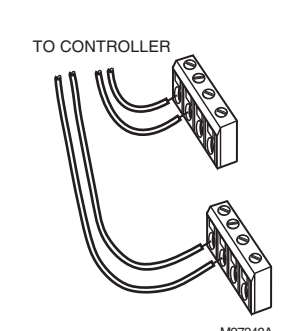

Fig. 5. Options for Wiring Multiple Zios.

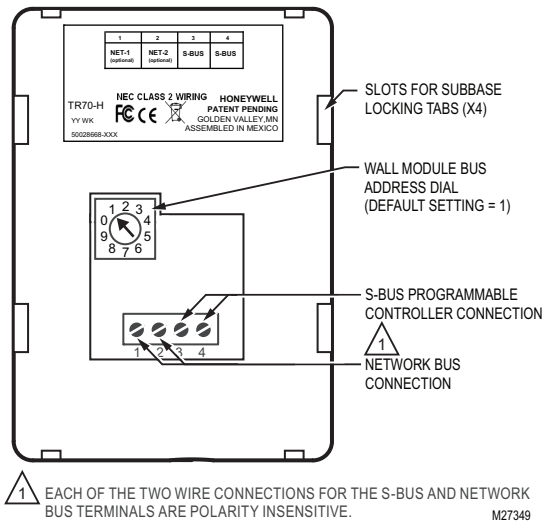

Fig. 6. Terminal connections, Wall Module bus address dial, and TR70-H address dial (rear view of LCD wall module).

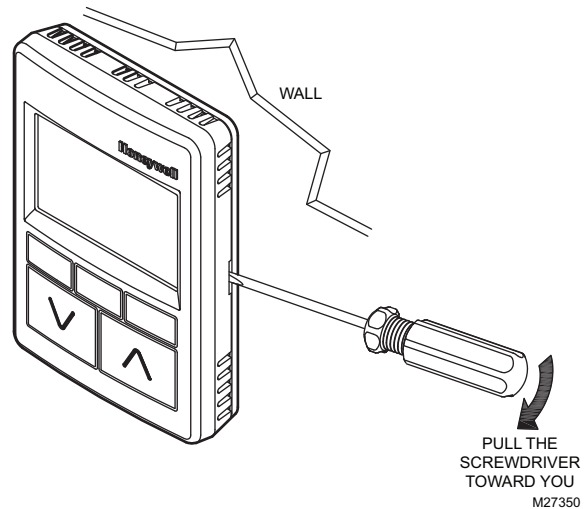

Fig. 7. Removing Wall Module from Subbase.

Setting the Wall Module Bus Address Dial

For the TR70, ensure that the wall module bus address dial is set to 1. For the TR71 or TR75 models, set the address to any number from 0 to 9. (A setting of 0 on Zio is equal to 10 in the Configuration Tool, so if the Zio is set to 0, set the address to 10 in the Configuration Tool.) Address must be different for each device on the Sylk bus. Use a thin blade screwdriver to turn the dial arrow. The address on the wall module must match the address in the tool. A maximum of four Zios may be wired on a single Sylk bus, with no more than one TR70 per bus.

Attaching the Wall Module to the Subbase

When all wiring is complete, press the LCD wall module straight down onto the subbase until it snaps into place.

Removing the Wall Module from Subbase

To remove the wall module from its subbase:

1. Insert a thin, flat-blade screwdriver into the slot on the right side of the wall module (see Fig. 7).
2. Pull the screwdriver toward you to release the right side of the wall module from the subbase.
3. Pull the wall module out and away from the subbase.

POWER UP

After the wall module is properly wired to the controller, it will power up. Upon initial power up, the wall module LCD panel displays the phrase, "PLEASE LOAD" (see Fig. 8). This phrase alternates with bus address, model and version number (TR71 and TR75 only), and any onboard sensor display, such as temperature, humidity, etc.

Refer to the *Zio LCD Wall Modules Operating Guide* (Form 63-2719) to configure and load the desired user interface and parameters into the wall module.

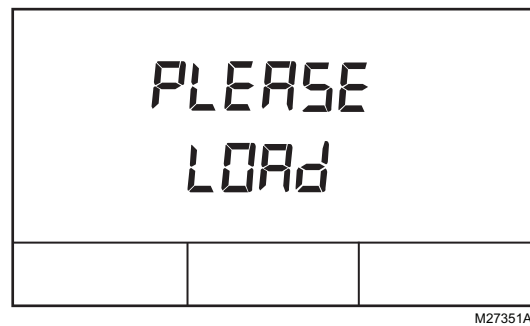

Fig. 8. Wall Module LCD display at initial power up.

ComfortPoint™ is a trademark of Honeywell International Inc.
LONMARK® is a trademark of the LonMark Association.
BACnet® is a trademark of BACnet International.
Sylk® is a trademark of Honeywell International Inc.
Zio® is a trademark of Honeywell International Inc.
CIPer™ is a trademark of Honeywell International Inc.
WEBs-AX™ and *WEBs-NX™* are trademarks of Honeywell International Inc.

Honeywell Building Technologies

In the U.S.:
 Honeywell

